

Basket
BAKERY
BAKERY CRATE

AtranVelo AB
Vinbergsvägen 4
311 50 Falkenberg
info@atranvelo.com

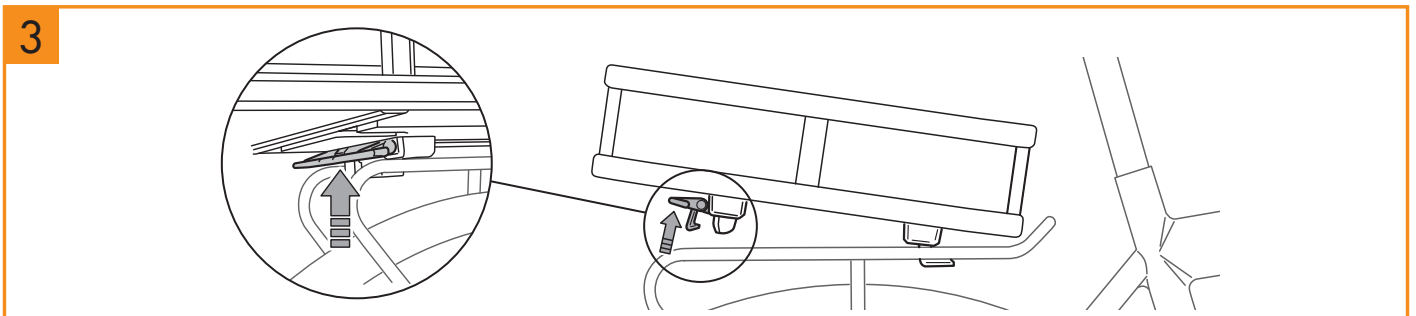

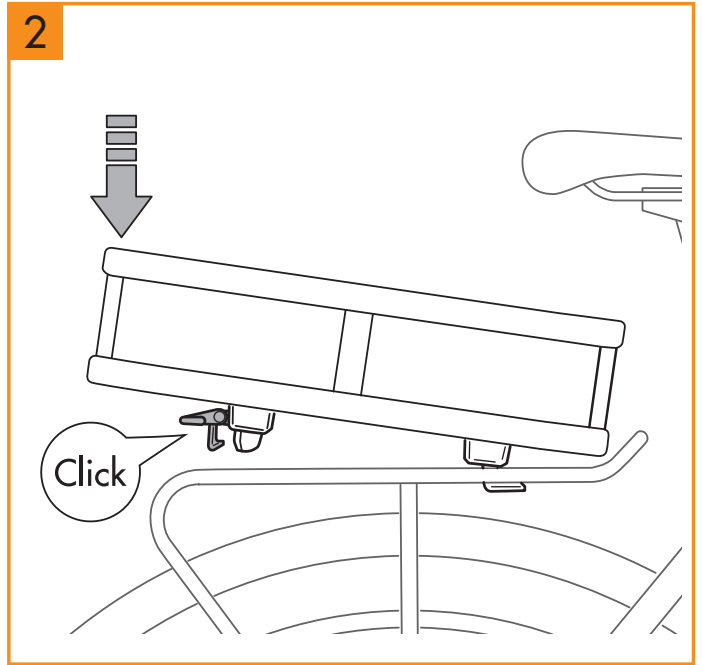
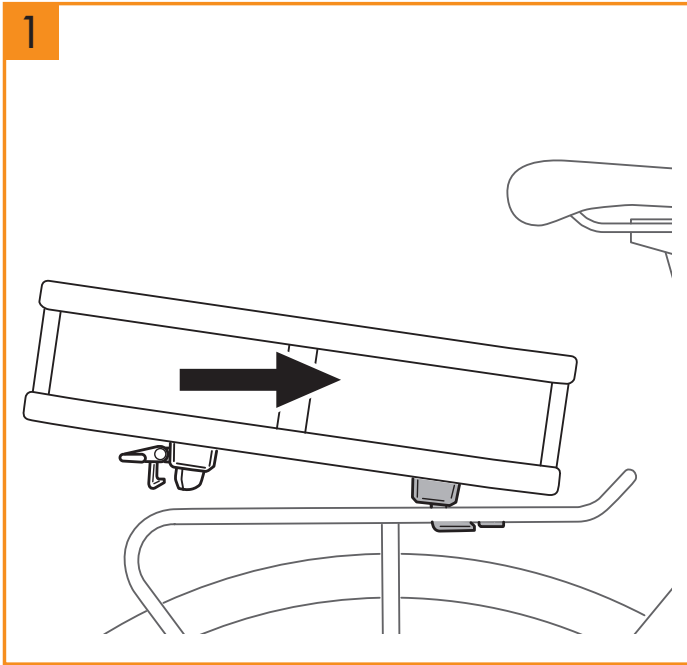
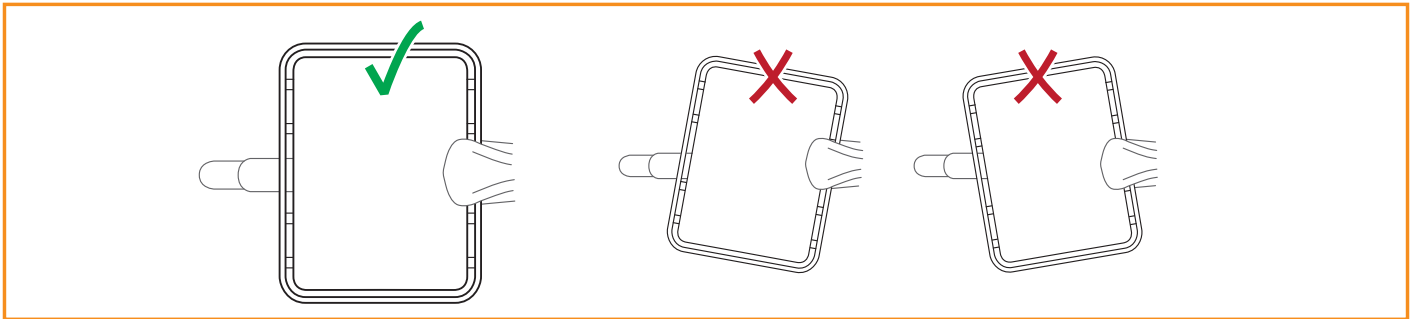
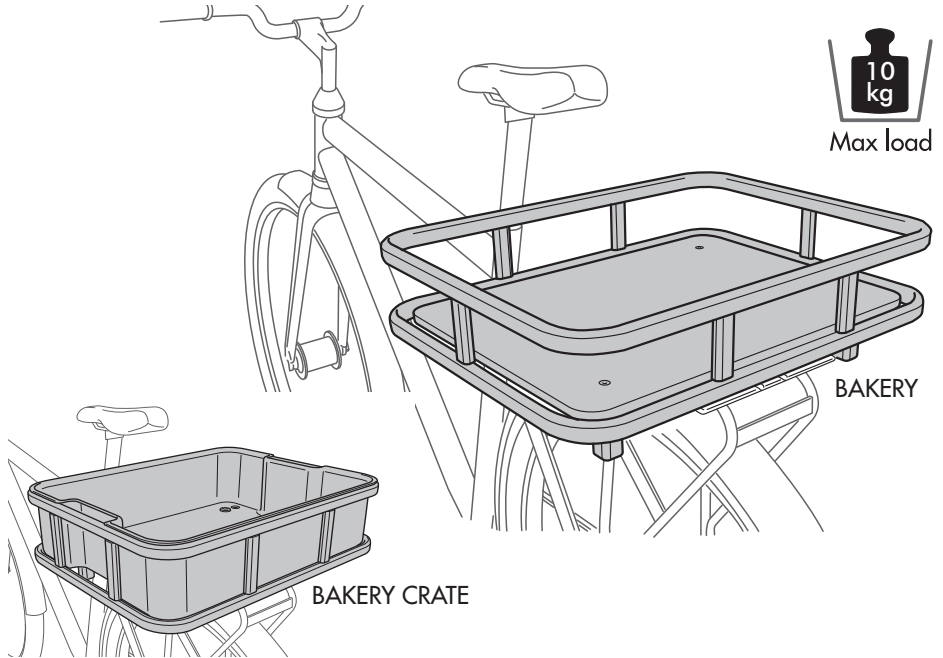
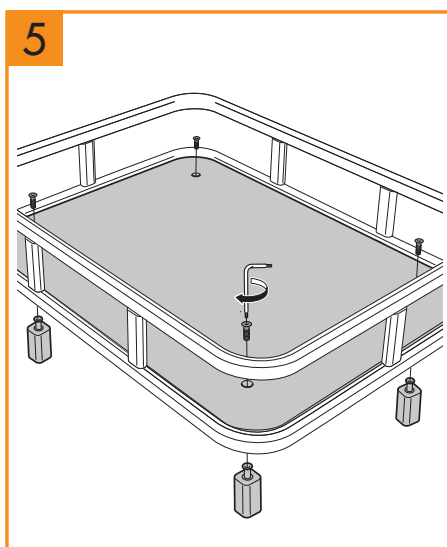
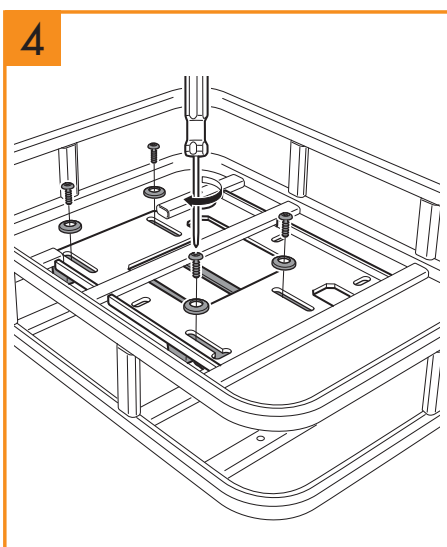
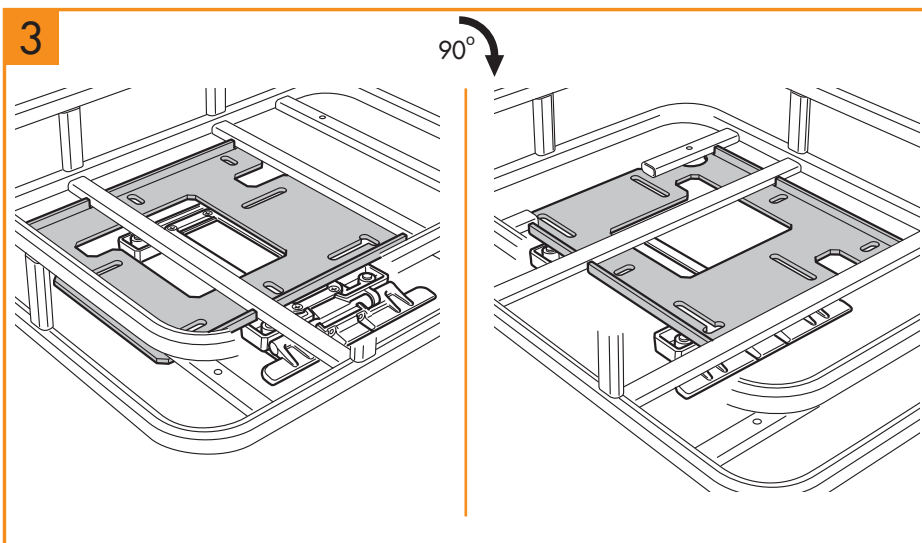
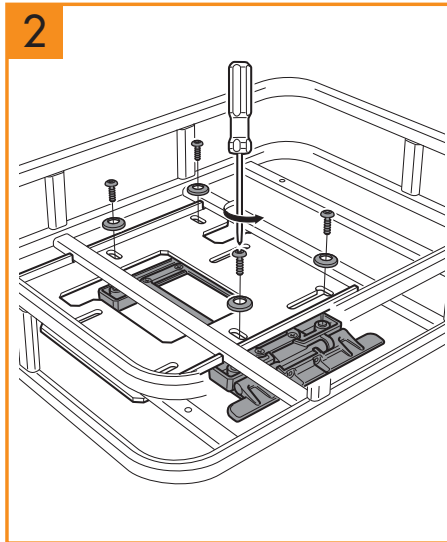
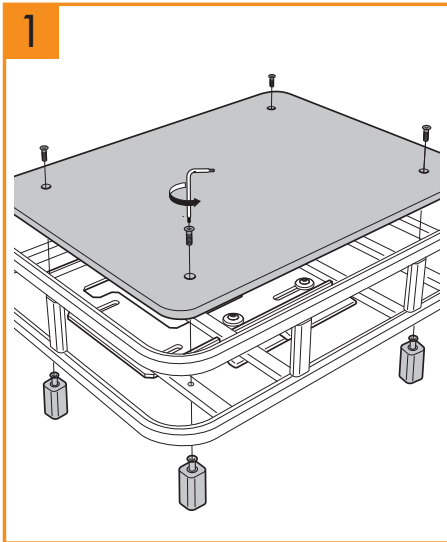
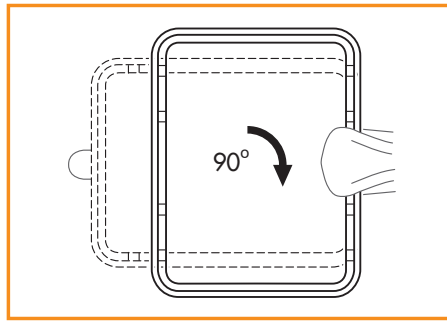
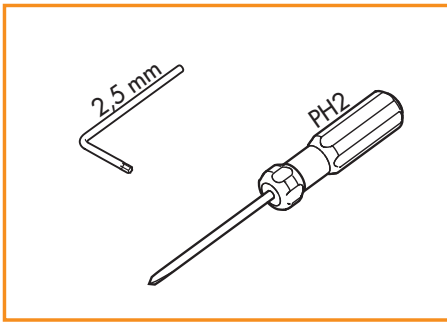

Information for the Bakery Basket

To get the most out of this product, follow the information and warning regulations carefully. This information shall be read and understood before use of the pet basket.

Maximum load capacity of this basket is 10 kg. **Under no circumstances shall the maximum load capacity be exceeded.**

Keep the instruction in a safe way so that you can return to the instruction if necessary.

Model: Basket DUO

Warning!

- Check the geometric data and the strength of the bicycle, on which the basket is to be mounted. Contact your dealer where the bicycle is bought for professional assessment and assistance if you are unsure.
- For safety reasons must the luggage carrier mounted on the bicycle have been approved according ISO 11243:2016 and in a weight class equal to, or above the maximum weight for the use of the basket. Pay attention to the point **a**, **d**, **e** and **f**.
- The basket, luggage carrier and associated fasteners should be checked regularly. Slightest sign of deviation shall be corrected immediately. Contact dealer where the basket and/or luggage carrier/ bicycle was purchased for a proper review and possible action.
- Right loaded, this basket is the safest way to transport luggage on a bicycle in the traffic. Check that there are no loose straps or pieces of luggage that can come down on/to the wheel while driving.
- Under no circumstances shall this basket be changed or modified. The warranty will be no longer valid once modifications have been made to the product or when the product has not been assembled or used according to the instruction supplied.
- The bike behaves differently when the basket is loaded and mounted on the AVS luggage carrier. Test ride several times in a safe location before heading out into the traffic. Be aware that special steering and braking are affected when the basket is loaded.
- Before start riding the bicycle, ensure that the luggage fitted to the basket is properly secured and that there are no loose straps or similar, that can get caught in the wheel.
- Always distribute the luggage as evenly as possible in the basket. Remember not to exceed the maximum load capacity.
- The type(s) of bicycles for which this basket are intended, is a vehicle that has at least two wheels and is propelled solely or mainly by the muscular energy of the person on that vehicle, in particular by means of pedals, or a equipped with pedals and an auxiliary electric motor, which cannot be propelled exclusively by means of this auxiliary electric motor, except in the start-up assistance mode